

SUPPLEMENT FOR RETROFITTING A REDESIGNED FPX SINGLE FLANGE SHAFT PUMP SHAFT AND/OR MOTOR REPLACEMENT



Start all pump disassembly by disconnecting the electrical power to the pump's electric motor. Observe all lock out/tag out procedures as outlined by ANSI Z244.1-1982 and OSHA 1910.147 to prevent accidental start-up and injury.

TOOLS REQUIRED FOR PUMP SHAFT AND/OR MOTOR REPLACEMENT:

Soft-faced mallet (5 lb. dead blow)
 15/16" socket wrench
 Two - 3/4" wrenches
 3/16" Allen wrench
 1/4" Allen wrench
 Screwdriver (flat blade)
 One set of feeler gauges
 Food grade lubricant
 Dial indicator
 Optional tools available through Fristam Pumps: shaft puller and gapping tool

REMOVING SHAFT (SHAFT AND SLEEVE DESIGN) - REFERENCES THE FPX SINGLE FLANGE MANUAL

- a) Disassemble the pump head as described on pages 9-10.
- b) Loosen the two 1/2" set screws in the shaft sleeve (6) with the 1/4" Allen wrench.
- c) Remove the 3/8" set screw from the sleeve with the 3/16" Allen wrench.
- d) Pull the pump shaft off the motor shaft. If necessary, rotate the pump shaft and tap with the soft-faced mallet to loosen the pump shaft from the motor shaft.

If the pump shaft does not pull off the motor shaft, the pump housing (14) and impeller (17) can be reinstalled to aid in removal (**Figure 20**). To do this, first ensure that the stationary seal (12) is not in the pump housing. Next install the pump housing onto the flange support (22). **DO NOT TIGHTEN THE FLANGE CLAMPING BOLT (4)**. Install the impeller onto the pump shaft and place a clean cloth or brass shim between the impeller and pump housing to prevent the impeller from scratching the pump housing during the shaft removal process. Thread the impeller nut (19) and impeller nut gasket (18) onto the shaft and tighten by hand. Now pull on the pump housing to loosen the pump shaft from the motor shaft. Tapping on the back of the pump housing with the soft-faced mallet may be required.

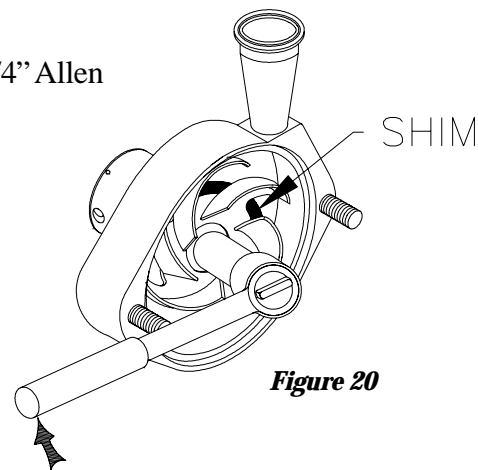

The use of the shaft puller, available from Fristam, is another method to remove the pump shaft.

ADDITIONAL INSTRUCTIONS FOR MOTOR REPLACEMENT -

Loosen the motor bolts (26). Remove the motor bolts and lock washers (25). Remove the flange support (2) and motor (1).

ASSEMBLING THE MOTOR TO THE FLANGE SUPPORT

If you have replaced the motor, clean off the motor face of the flange support (2). Place the flange support on the new motor, replace the motor bolts (26) and lock washers (25). Tighten the motor bolts to 30 ft-lb. for 143TC-145TC motor frames or 50 ft-lb. for 182TC-256TC motor frames.

ASSEMBLING THE NEW PUMP SHAFT TO THE MOTOR SHAFT - REFERENCES THE FPX SINGLE FLANGE (SHAFT COLLAR DESIGN) MANUAL

Note: when replacing the shaft, replace the shaft collar at the same time.

- a) Slide the new shaft collar (37) onto the pump shaft, do not tighten the shaft collar screw at this time.
- b) Slide the pump shaft assembly onto the motor shaft with the hole in the pump shaft aligned with the key in the motor shaft.
- c) Tighten the shaft collar screw (36) (**Figure 24**).

Figure 24

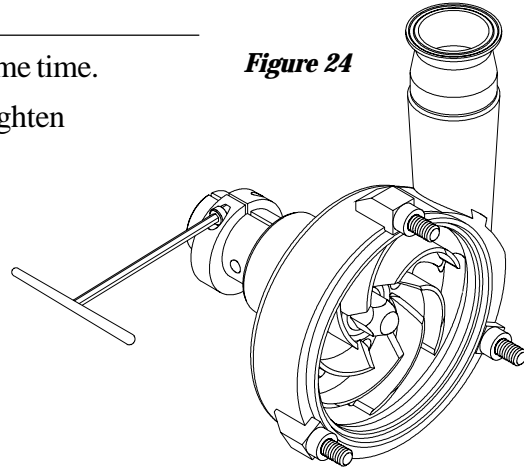

Proper torque for shaft collar screw:

Shaft collar screw	15 ft.-lb	(for 143TC - 184 TC motor frames)
Shaft collar screw	30 ft.-lb	(for 182 TC-256 TC motor frames)

126500081
12/1/02

To set the impeller gap and complete the pump assembly, please use the FPX Single Flange manual (shaft collar design) Re-order #001. Contact Fristam Pumps Marketing Department for a copy or download from the web site: <http://www.fristampumps.com/americas/literature.htm>

FPX SINGLE FLANGE EXPLODED VIEW (WITH SHAFT COLLAR)

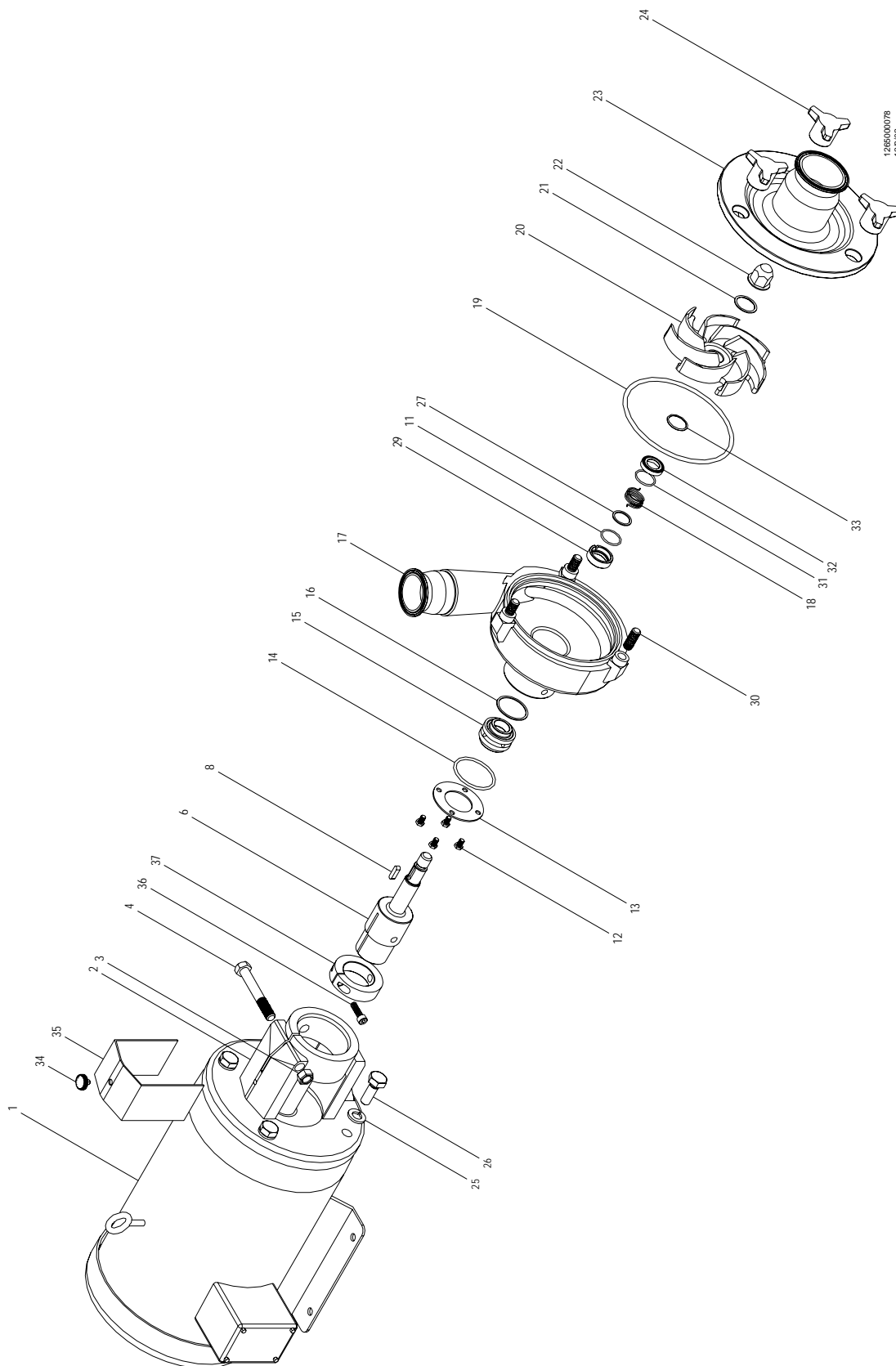



© Copyright 2004 - R3 - Fristam Pumps USA Limited Partnership
Reorder # - 153
Visit www.fristam.com for a current list of literature.

2410 Parview Road • Middleton, WI 53562-2524
1-800-841-5001 • 608-831-5001
Website: <http://www.fristam.com>
Email: fristam@fristampumps.com